

Lifter pin  
Elevador de banda

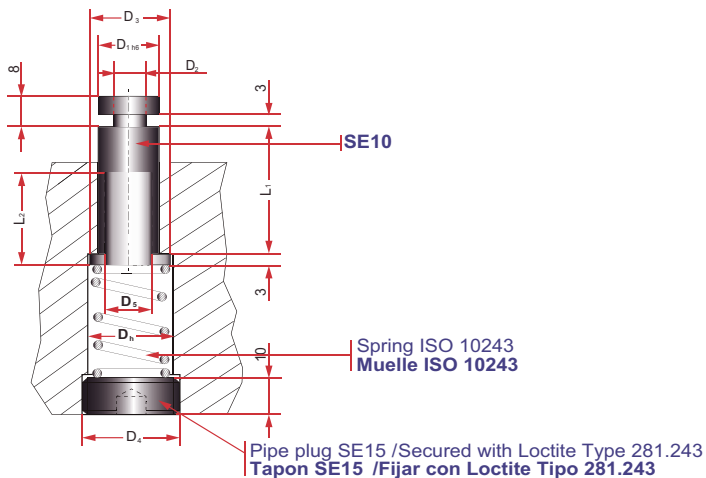

$D_1$	$D_2$	$D_3$	$D_h$	$D_4$	$D_5$	$L_1$	$L_2$	L	Plug Tapón	REF.
8	5	10	10,5	M12x1,5	-	20	-	31	SE15-M12	SE10-0820-M12
						25		36		SE10-0825-M12
						32		43		SE10-0832-M12
						40		51		SE10-0840-M12
10	6	12	12,5	M14x1,5	6,5	25	18	36	SE15-M14	SE10-1025-M14
						32	24	43		SE10-1032-M14
						40	30	51		SE10-1040-M14
						50	40	61		SE10-1050-M14
13	7	16	16,5	M18x1,5	8,5	25	18	36	SE15-M18	SE10-1325-M18
						32	24	43		SE10-1332-M18
						40	30	51		SE10-1340-M18
						50	40	61		SE10-1350-M18
16	8	20	20,5	M22x1,5	10,5	32	24	43	SE15-M22	SE10-1632-M22
						40	30	51		SE10-1640-M22
						50	40	61		SE10-1650-M22

Mounting example  
Ejemplo de montaje

