

Tunnel gate insert  
 Inserto de inyección  
 Wkładka tunelowa  
 Postiço de injeção  
 Embout d'injection cylindrique

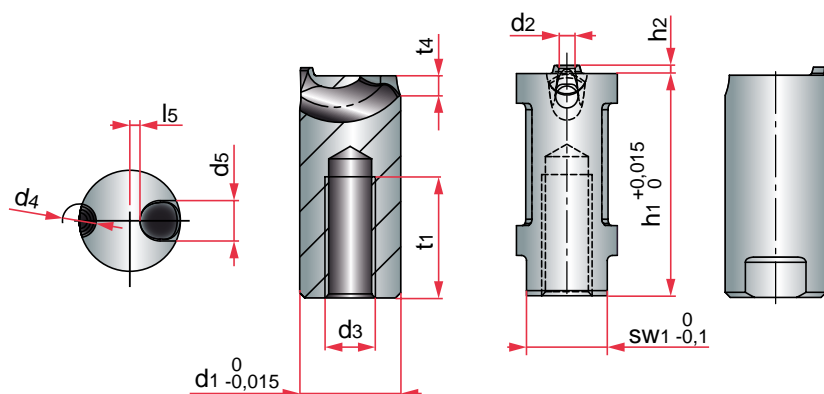

Hardness: 54 ± 2 HRC.

| SW1 | t1 | t4   | l5   | h2  | d3 | d4  | d5  | d1 | h1 | d2  | REF.                   |                        |
|-----|----|------|------|-----|----|-----|-----|----|----|-----|------------------------|------------------------|
| 5,5 | 10 | 1,25 | 0,5  | 0,6 | M4 | 2,2 | 2,5 | 6  | 17 | 0,6 | BR1050 / 6 x 17 x 0,6  |                        |
| 6   | 13 | 1,5  | 0,75 |     |    |     | 3   |    |    |     | 8                      | 22                     |
| 8   | 12 | 2    | 1    | 0,8 | M5 | 2,5 | 4   | 10 |    |     | BR1050 / 8 x 22 x 0,8  |                        |
|     |    |      |      |     |    |     |     |    |    |     | BR1050 / 10 x 22 x 0,8 |                        |
|     |    |      |      |     |    |     |     |    |    |     | 1,2                    | BR1050 / 10 x 22 x 1,2 |
| 10  | 11 | 2,5  |      |     |    | 2,9 | 5   | 12 |    |     | 1,6                    |                        |
|     |    |      |      |     |    |     |     |    |    |     | BR1050 / 10 x 22 x 1,6 |                        |
|     |    |      |      |     |    |     |     |    |    |     | 1,2                    | BR1050 / 12 x 22 x 1,2 |
|     |    |      |      |     |    |     |     |    |    |     | 1,6                    | BR1050 / 12 x 22 x 1,6 |
|     |    |      |      |     |    | 3,3 |     |    |    |     | 1,6                    |                        |
|     |    |      |      |     |    | 3,7 |     |    |    |     | 2,0                    |                        |
|     |    |      |      |     |    |     |     |    |    |     | BR1050 / 12 x 22 x 2,0 |                        |



Tunnel gate insert  
 Inserto de inyección  
 Wkładka tunelowa  
 Postiço de injeção  
 Embout d'injection rectangulaire

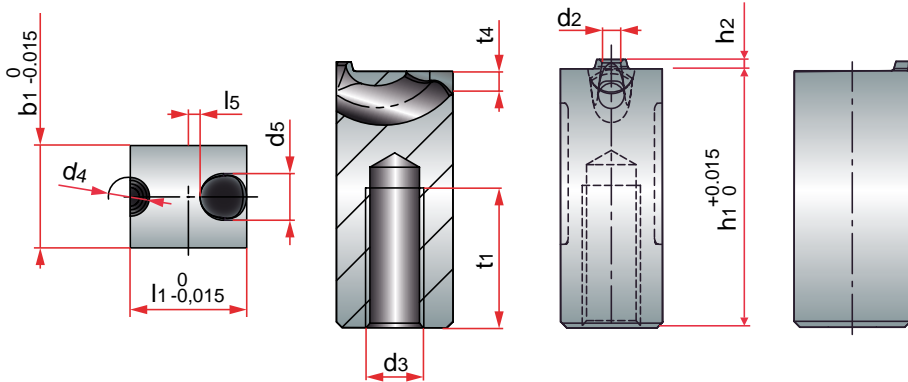

Hardness: 54 ± 2 HRC.

| t1 | t4  | l5   | h2  | d3 | d4  | d5 | l1 | b1 | h1 | d2  | REF.                       |
|----|-----|------|-----|----|-----|----|----|----|----|-----|----------------------------|
| 13 | 1,5 | 0,75 | 0,6 | M4 | 2,2 | 3  | 8  | 6  | 22 | 0,6 | BR1060/ 8 x 6 x 22 x 0,6   |
|    |     |      |     |    | 2,4 |    |    |    |    | 0,8 | BR1060/ 8 x 6 x 22 x 0,8   |
| 12 | 2   | 1    | 0,8 | M5 | 2,5 | 4  | 10 | 8  |    | 1,2 | BR1060/ 10 x 8 x 22 x 0,8  |
|    |     |      |     |    | 3   |    |    |    |    | 1,6 | BR1060/ 10 x 8 x 22 x 1,2  |
|    |     |      |     |    | 3,3 |    |    |    |    | 1,2 | BR1060/ 10 x 8 x 22 x 1,6  |
|    |     |      |     |    | 3,7 |    |    |    |    | 1,6 | BR1060/ 10 x 8 x 22 x 2,0  |
| 11 | 2,5 |      |     |    | 2,9 | 5  | 12 | 10 |    | 1,2 | BR1060/ 12 x 10 x 22 x 1,2 |
|    |     |      |     |    | 3,3 |    |    |    |    | 1,6 | BR1060/ 12 x 10 x 22 x 1,6 |
|    |     |      |     |    | 3,7 |    |    |    |    | 2,0 | BR1060/ 12 x 10 x 22 x 2,0 |
|    |     |      |     |    |     |    |    |    |    |     |                            |

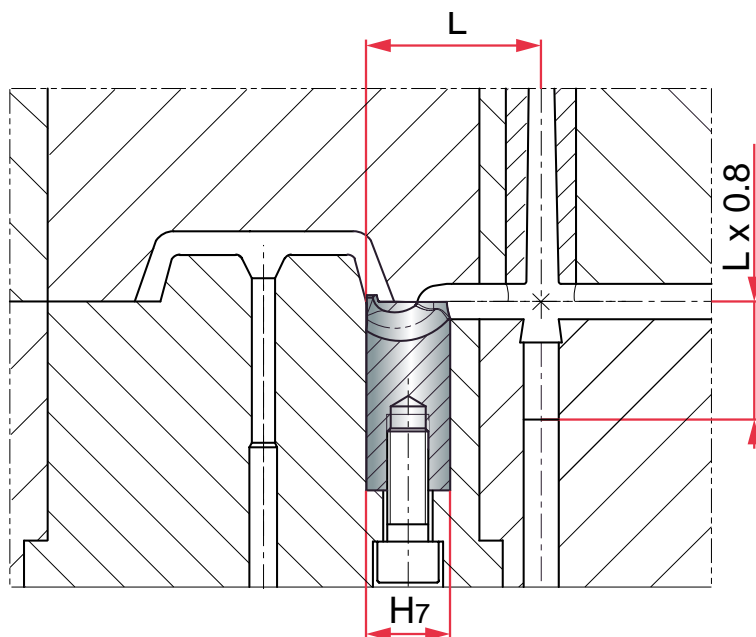

| Distance L (mm) |                  |                         |                             | REF.         |              |
|-----------------|------------------|-------------------------|-----------------------------|--------------|--------------|
| TPE, TPU, TPA   | PE, PP, PET, PBT | ABS, PA, POM,<br>ABS/PC | PA+GF, PC, SAN,<br>PMMA, PS | BR1050/ ...  | BR1060/ ...  |
| 9 - 11          | 12 - 18          | 15 - 22                 | 18 - 25                     | ... 6 x ...  | -            |
| 11 - 14         | 15 - 22          | 19 - 27                 | 23 - 30                     | ... 8 x ...  | ... 8 x ...  |
| 15 - 18         | 19 - 27          | 24 - 33                 | 30 - 38                     | ... 10 x ... | ... 10 x ... |
| 18 - 21         | 22 - 30          | 27 - 36                 | 32 - 41                     | ... 12 x ... | ... 12 x ... |

# BR1050/BR1060

Gate diameter recommendation  
Diámetro recomendado

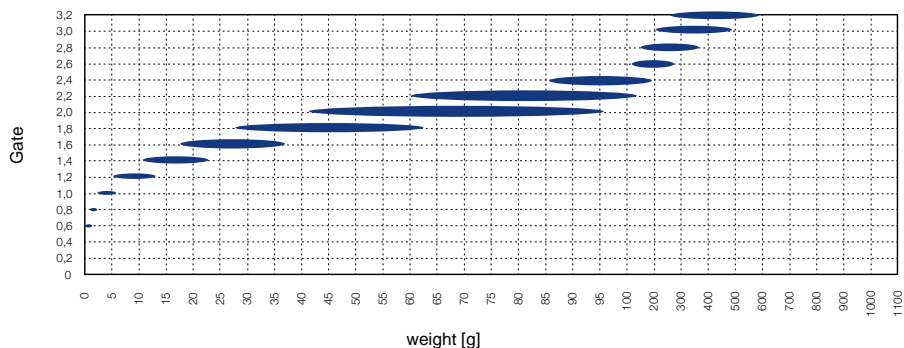

Medium Viscosity

ABS, SAN, POM-CO, PMMA, EPDM, PA, PBT, PET

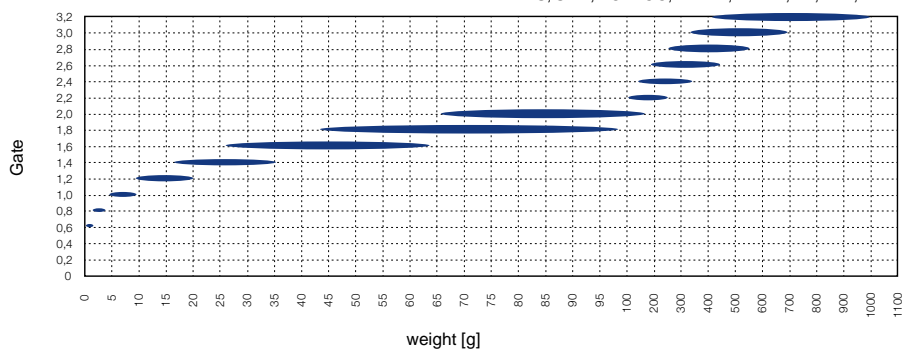

Low Viscosity

PP, PE, PS, SB

